



NATIONAL  
ENDOWMENT  
FOR THE  
HUMANITIES

DIVISION OF PRESERVATION AND ACCESS

## **Narrative Section of a Successful Application**

The attached document contains the grant narrative of a previously funded grant application. It is not intended to serve as a model, but to give you a sense of how a successful application may be crafted. Every successful application is different, and each applicant is urged to prepare a proposal that reflects its unique project and aspirations. Prospective applicants should consult the NEH Division of Preservation and Access application guidelines at <http://www.neh.gov/divisions/preservation> for instructions. Applicants are also strongly encouraged to consult with the NEH Division of Preservation and Access staff well before a grant deadline.

Note: The attachment only contains the grant narrative, not the entire funded application. In addition, certain portions may have been redacted to protect the privacy interests of an individual and/or to protect confidential commercial and financial information and/or to protect copyrighted materials.

**Project Title:** Improving energy efficiency in collection storage in Spencer Research Library,  
University of Kansas

**Institution:** The University of Kansas Center for Research, Inc.

**Project Director:** Whitney Baker

**Grant Program:** Sustaining Cultural Heritage Collections

## INTRODUCTION

The University of Kansas (KU) Libraries seeks a Sustaining Cultural Heritage Collections Implementation Grant from the National Endowment for the Humanities (NEH) to complete the second phase of a multi-phased approach to updating the heating, ventilation, and air conditioning system (HVAC) in Spencer Research Library, which houses the University's archival and special collections. In 2017, for Phase 1 of the project, the KU Libraries was awarded a Sustaining Cultural Heritage Collections Planning Grant. Consultants from Image Permanence Institute (IPI) collected extensive data over eighteen months and provided recommendations for improving energy savings in the building while protecting the collections. The addition of nightly setbacks and increased maintenance attention has already led to a 40% reduction in energy costs for Spencer Library.

We hope to continue the momentum into Phase 2, outlined here, in order to implement some of the recommendations in IPI's consultant report. The long-term goal of the project is to update the entire HVAC system, which is original to the 1968 building. In the current proposal, we aim to replace the pneumatically controlled reheats in collection areas of the building (approximately two-thirds of the building's area) with modern electric reheats, variable air volume (VAV) dampers, and new direct digital controls (DDC) as a first step in eventually replacing the entire air handling system. Phase 2 will also include testing and balancing the system and monitoring the temperature and relative humidity through the shoulder seasons and summer to ensure that the new equipment operates smoothly.

The new equipment will allow for better temperature and humidity control in the building and the ability to keep collection storage spaces at a lower temperature than staff areas. It is independent of the air handler and will continue to remain in operation when we enter Phase 3: the eventual replacement of the air handling unit (AHU) itself. The ultimate goal of the project is to preserve the collections and the facility while reducing the environmental impact of the building's operations. KU's energy engineer estimates that Phase 2 of the project will reduce building energy costs by an additional 10-12% per year.

The University of Kansas (KU) in Lawrence, Kansas, was founded in 1864, shortly after Kansas entered the Union in 1861. One of the earliest public universities to admit men and women equally, KU's student body today hails from all 50 states and 110 countries. KU is the only Kansas Regents University to hold membership in the prestigious Association of American Universities (AAU), a select group of 36 public research universities (and 62 overall) that represent excellence in graduate and professional education and the highest achievements in research as a Research I institution. Current enrollment is over 28,000 students, with more than 200 undergraduate majors in the sciences, arts, and humanities.

The University of Kansas Libraries' mission is to "lift students and society by educating leaders, building healthy communities and making discoveries that change the world." The Libraries comprise seven facilities across the main campus and hold over 5.6 million titles. In fiscal year 2019, the Libraries had a staff of 138 and a combined operating budget of \$21,854,000. Collection development is undertaken by a team of librarian subject specialists who direct and shape the library collections. In 2017, KU Libraries developed a two-year focus map (<https://lib.ku.edu/focus-map>) to direct its priorities, one goal of which is to "improve the discoverability, use, and durability of our unique and distinctive resources." The Libraries is currently developing strategic initiatives to guide the institution through the next few years. In late 2019, KU's Chancellor announced a new strategic planning process for the university beginning in 2020 (<https://ku.edu/strategic-planning-2020>).

Kenneth Spencer Research Library (Spencer), part of the KU Libraries system, houses rare book, manuscript, and archival collections. The staff of twenty-two librarians, archivists, and catalogers work collaboratively with faculty, researchers, and staff across the library system and the larger campus on initiatives such as digital imaging, preservation of resources in all formats, and support for the research enterprise. The particular strengths Spencer Library brings to the broader Libraries' mission are its diverse collections; a long history of creative, ambitious, and successful collection development; and a

commitment to preservation and access.

KU Libraries, with extensive support from the University's Facilities staff, has addressed and partially or fully resolved many environmental challenges in Spencer Library relating to airflow, building envelope issues, control of natural and interior lighting, and physical security of collections. We have secured off-site cold storage for audiovisual formats, updated some windows with modern versions that include an internal ultraviolet (UV) radiation-blocking layer, installed curtains in some areas to reduce visible and UV radiation, and eliminated sources of water seepage into collection areas. The major challenge still confronting Spencer Library is the original HVAC system: an air handling unit that was designed to produce chilled air, with pneumatic reheats dispersed throughout the building for temperature and humidity control, all within a single-zone system. The 2017 Sustaining Cultural Heritage Collections Planning Grant represented Phase 1 of the project: to analyze the air handling unit and its supporting systems to better understand the issues and to develop possible solutions for creating a sustainable preservation environment. Based on extensive testing and analysis, the consultant recommendations will assist the Libraries in addressing these issues in Phase 2.

### **SIGNIFICANCE OF THE COLLECTIONS**

In 1966, Kansas City philanthropist Helen Foresman Spencer awarded the University of Kansas two million dollars to build a rare book and manuscripts library in honor of her husband, Kenneth. The KU Chancellor at the time noted that "as the University grows, the Spencer Library will take its place among the finest special research libraries in the country. It will contain the best available temperature and humidity controls for proper preservation of the scarce and fragile records of human endeavor" (*Kansas Alumni*, February 1966). Completed in 1968, the neoclassical Kenneth Spencer Research Library boasts 85,000 square feet of net assignable space, including four and a half floors of collections storage, a reading room, three classrooms, staff offices, collections processing spaces, conservation laboratories, and a 400-foot, glassed-in gallery space with visible book stacks reminiscent of a similar gallery at the Beinecke Library at Yale University.

The extensive and varied collections of Spencer Research Library broadly and deeply support exploration, teaching, and research in the humanities, connecting scholars with original records of human experience as varied as cuneiform tablets, 18th century newspapers, pictorial records of 19th century industrial and rural environments, and manuscripts of contemporary science fiction authors. Holdings include over 350,000 printed books; 500,000 manuscripts; 58,000 linear feet of archival records; 2 million historical photographs; and tens of thousands of items in audio, video, and film formats. Strengths of the rare book and manuscript collections have resulted from areas of teaching excellence at KU, such as literature, languages, history, history of science, science fiction, and Kansas and the Great Plains.

Examples of unique and outstanding collections supporting humanities scholarship include:

#### ***Contemporary political movements***

One of Spencer Library's most frequently used collections, the Wilcox Collection of Contemporary Political Movements contains a wide variety of left- and right-wing United States publications from the 1950s to the present, including extensive ephemera available only at the University of Kansas. The collection documents various viewpoints on race, civil rights, student protests, abortion, communism, socialism, gun control, taxation, and hate groups, and features materials on the rights of women, Indigenous Americans, and African Americans, as well as individuals identifying as lesbian, gay, bisexual, transgender, and queer (LGBTQ). The Wilcox holdings encompass over 10,000 books, pamphlets, and periodicals; 800 audio tapes; 73 linear feet of manuscript materials; more than 100,000 pieces of ephemera, including thousands of zines. It complements similar collections at the Wisconsin Historical Society, UCLA, Michigan, Iowa, and Brown, among others, although Spencer Library's holdings are

among the most extensive. In 2015, Spencer Library hosted a scholarly exhibit on the Wilcox Collection, titled *Free Speech in America: The Wilcox Collection at 50* (<http://exhibits.lib.ku.edu/exhibits/show/wilcox--free-speech>). Significant works produced with research from the Wilcox Collection include:

- Mulloy, Darren J. *Enemies of the State: The Radical Right in America from FDR to Trump*. Lanham, MD: Rowman and Littlefield, 2018.
- Mulloy, Darren J. *The World of the John Birch Society: Conspiracy, Conservatism, and the Cold War*. Nashville: Vanderbilt University Press, 2013.
- Bennett, David H. *The Party of Fear: From Nativist Movements to the New Right in American History*. New York: New York University Press, 2005.

### **Irish collections**

Spencer Library's Irish materials represent one of the most significant and sizable collections of rare Irish materials outside of Ireland, rivaled only by the University of Notre Dame and Boston College. The backbone is the 25,000-item library of P.S O'Hegarty, former Secretary of the Irish Post Office, with incredible depth in Irish literature, history, and politics, including periodicals and ephemera from the 17<sup>th</sup> century to the revolutionary movements of the 20<sup>th</sup> century. The collection is rich in books, periodicals, newspapers, broadsides and other ephemera, political pamphlets, local history publications, songs, and scholarly works. Additional strengths of the Irish collections include:

- James F. Spoerri Collection of James Joyce, numbering over 900 items. The collection is unusually complete in printed material in both book and periodical form, including all first editions of Joyce's works except for five minor items.
- W. B. Yeats Collection, containing all but two of his works in first edition, numerous periodical publications, and several score of books from his personal library (including copies of his own works with his annotations). Spencer also holds a manuscript collection of Yeats family correspondence.

Recent publications produced with research from the Irish collections include:

- Griffith, Angela, Marguerite Helmers, and Roisin Askale Kennedy, eds. *Harry Clarke and Artistic Visions of the New Irish State*. Kildare, Ireland: Irish Academic Press, 2019.
- Conrad, Kathryn, Colin Parsons, and Julie McCormick Weng, eds. *Science, Technology, and Irish Modernism*. Syracuse, New York: Syracuse University Press, 2019.
- Helmers, Marguerite H. *Harry Clarke's War: Illustrations for Ireland's Memorial Records, 1914-1918*. Kildare, Ireland: Irish Academic Press, 2016.
- Flanagan, Frances. *Remembering the Revolution: Dissent, Culture, and Nationalism in the Irish Free State*. Oxford University Press, 2015.

In addition, this collection supports classes taught in Irish literature in the Department of English. Spencer's collections have been featured by the Kansas City Irish Center, Kansas City Irish Fest, and the Midwest American Conference for Irish Studies. The collections supported a recent scholarly exhibit in Spencer Library, *Easter 1916: Rebellion and Memory in Ireland* (<http://exhibits.lib.ku.edu/exhibits/show/easter-1916>).

### **Renaissance, early modern, and eighteenth-century imprints**

The Summerfield Collection of Renaissance and Early Modern Books printed in Continental Europe, 1455-1700, has grown during six decades of collecting to include more than 9,500 titles in history, literature, law, science, theology, and the arts. These works are also rich sources for the early history of the printed book, and the collection includes 145 incunabula (from the first fifty years of European printing). In addition, the 18<sup>th</sup> century in England and France is a period of particular strength for Spencer Library. Its collection of eighteenth-century English imprints is one of the largest in North

America as reported to the *English Short Title Catalog* (ESTC), and is strong in politics, economics, literature, and natural history. Additional strengths in the Renaissance and early modern era are:

- The Cervantes Collection, serving as an excellent vehicle for introducing visiting Spanish classes to *Don Quixote* and its many editions, in multiple languages, as well as a host of chapbook versions, versifications, scholarly editions, and dramatizations.
- Over 9,000 pamphlets pertaining to the French Revolution, the majority of which were published in France between 1787 and 1800.
- Over 900 titles brought out by Edmund Curll (1675-1747), an eighteenth-century bookseller and publisher notorious for his unscrupulous publication practices. Spencer Library holds one of the most complete collections of Curll's output, alongside that of the British Library.

Recent publications produced with research from Spencer's Renaissance and early modern imprints include:

- Brink, Jean R. *The Early Spenser; 1554-80 'Minde on honour fixed'*. Manchester: University of Manchester Press, 2019.
- Van Hensbergen, Claudine. "Unlocking *The Cabinet of Love*: Rochester, Reputation, and the Eighteenth-Century Miscellany." *Eighteenth-Century Life* 41:1 (January 2017): 56–75.
- Bergeron, David M. *Shakespeare's London 1613*. Manchester: Manchester University Press, 2017.
- Lamb, Jonathan P. "Ben Jonson's Dead Body: Henry, Prince of Wales, and the 1616 Folio." *Huntington Library Quarterly* 79:1 (Spring 2016).

Imprints from the Renaissance and early modern eras are frequently used in classroom instruction, including classes taught in Spencer on Shakespeare, History of the Book, and in languages and literature.

### **History of science**

Spencer Library boasts extensive and deep holdings in the history of science. The Ellis Collection of literature pertaining to natural history, especially ornithology, consists of some 15,000 bound volumes, as well as pamphlets, letters, original drawings, manuscripts, and other miscellanea. In particular, the collection includes nearly complete holdings of the books that John Gould (the "English Audubon") published about the birds of the world during the mid-19<sup>th</sup> century, along with about 2,500 preliminary drawings and watercolors, lithographic stones, and proof prints produced by Gould and his atelier. This unique material comprises about 90% of surviving Gould prepublication material worldwide. An NEH grant enabled cataloging, conservation, digital photography, and display at the University of Kansas Libraries' website of the entire John Gould Ornithological Collection (<http://luna.ku.edu/luna/servlet/kuluna01kui~19~19>).

Recent humanities-based publications from history of science collection include:

- Oppenheimer, Joel, Laura Oppenheimer, and Robert McCracken Peck, eds. *The Family of Hummingbirds: The Complete Prints of John Gould*. New York: Rizzoli Electa, 2018.
- Ashley, Melissa. *The Birdman's Wife*. South Melbourne, Australia: Affirm Press, 2016.
- Peck, Robert McCracken. *The Natural History of Edward Lear (1812-1888)*. Jaffrey, New Hampshire: David R. Godine, 2016.

Materials from the Gould Collection were featured in the recent scholarly exhibit, *John Gould: Bird Illustration in the Age of Darwin* (<http://exhibits.lib.ku.edu/exhibits/show/gould>).

### **Latin American collections**

Extensive Latin American holdings at Spencer are especially strong in Central America, Paraguay, and Brazil, including many unique broadsides, campaign posters, and other ephemeral materials. The most significant collections are:

- The William J. Griffith Collection of Guatemala and Central America, which is remarkably comprehensive in Guatemalan print, ephemeral, and manuscript materials from the late eighteenth to early twentieth century and features significant material from Costa Rica, Nicaragua, Honduras, and El Salvador. *Central American Broadsides*—election materials, political manifestos, and government pronouncements from the 1820s to 1920s—were recently digitized and made available online (<https://digital.lib.ku.edu/ku-broadsides/root>). This collection rivals holdings at Tulane, the University of Texas at Austin, and the University of California, Berkeley.
- Printed and manuscript materials documenting the turbulence in late-eighteenth- and nineteenth-century Portuguese and Brazilian politics.
- Personal papers of Natalicio González, a historian, poet, and former President of Paraguay, as well as originals and transcripts of materials relating to Paraguayan history and politics.

### **Science fiction**

Science fiction collections have developed over decades with the assistance of noted scholar and author James E. Gunn (Science Fiction Writers of America Grand Master and founder of KU's Gunn Center for the Study of Science Fiction). Holdings include near complete runs of major and minor periodicals, as well as more ephemeral fanzines; audio visual materials including several hundred oral history tapes from the Science Fiction Oral History Association; and important paperback editions such as the Ace Doubles series. Other notable collections include:

- Manuscript collections from authors Theodore Sturgeon, Cordwainer Smith, Donald A. Wollheim, and Brian Aldiss, among others.
- Corporate records of the Robert Mills Literary Agency, for over 200 science fiction and fantasy and genre writers, offering insight into the business dimensions of science fiction production.

Science fiction materials have been featured as part of many symposia and scholarly conferences, including the Lawrence (KS) Public Library's 2016 panel on the "Science of Science Fiction," the annual Campbell Conference for Science Fiction held at KU, and the 2016 WorldCon (World Science Fiction Convention) held in nearby Kansas City, MO. Recent publications using materials from Spencer's science fiction collections include:

- *Théodore Sturgeon, le plus qu'auteur: Plongée dans l'univers d'un humaniste de la SF: Interviews, témoignages exclusifs, archives, essais, analyses*. Haguenuau: Forum les débats; Chambéry: Actusf, 2018
- Gunn, James E. *Alternate Worlds: The Illustrated History of Science Fiction*. Third Edition. Jefferson, North Carolina: McFarland & Company, Inc., 2018.
- Page, Michael R. *Saving the World through Science Fiction: James Gunn, Writer, Teacher and Scholar*. Jefferson, North Carolina: McFarland & Company, Inc., 2017.
- Hageman, Andrew. "A Generic Correspondence: Sturgeon–Roddenberry Letters on SF, Sex, Sales and *Star Trek*." *Science Fiction Film & Television* 9:3 (Oct 2016): pp. 473-478.

Spencer Library's holdings complement resources elsewhere in the state and the nation, as demonstrated by digital projects that combine its resources with those at other institutions. *Digital Scriptorium* (<http://www.digital-scriptorium.org/>) hosted by Columbia University, features many of Spencer's medieval manuscript holdings. *Territorial Kansas Online* ([www.territorialkansasonline.org/](http://www.territorialkansasonline.org/)) is an interactive website developed by Spencer Library and the Kansas State Library to make accessible the best of both institutions' holdings from the territorial period of Kansas history (1854–1861). Spencer Library is also a project partner in two digital initiatives to document the border conflict between Kansas and Missouri leading up to and during the U.S. Civil War: *Community and Conflict: The Impact of the Civil War in the Ozarks* (<http://www.ozarkscivilwar.org/>) from the Springfield-Greene Library, Missouri, and *Civil War on the Western Border* (<http://www.civilwaronthewesternborder.org/>), hosted by the Kansas

City Public Library and Missouri State Library.

Spencer's updated exhibition space opened in 2012. Educators across campus have incorporated Spencer exhibitions into classroom use. A digital exhibition of most physical exhibits and "collection features" is created using Omeka software. In the spring of 2017, an additional exhibition space opened on the bottom level of the glassed-in North Gallery, converting former visible storage into an interactive exhibition space. The extensive gallery highlights Spencer's collecting strengths and allows Spencer to share selected books, manuscripts, objects, ephemera, and audio and video clips. The space functions as an orientation to Spencer's resources for KU classes, a self-guided tour experience for visitors, and an exceptional program and reception space.

### **Collection usage**

In fiscal year 2019, 7,603 people visited Spencer Library for research, tours, classes, and events. Of that number, 963 patrons visited the reading room for research, with an average of three and a half hours per visit and a total of 5,396 items requested for use in the reading room.

Spencer Library has three classrooms that are in near constant use during the fall and spring semesters. In fiscal year 2019, Spencer staff taught 171 classes (with 2,347 total attendees) for departments across the campus, including humanities-based classes in African and African American Studies; American Studies; Classics; Curriculum and Instruction; English; Environmental Studies; French; History; History of Art; Honors Program; Humanities; Italian; Jewish Studies; Journalism; Music Education and Music Therapy; Museum Studies; Philosophy; Photo Media; Portuguese; Religious Studies; Spanish; Theater; Visual Art; and Women, Gender, and Sexuality Studies. Spencer staff selected 2,138 items to use in these classes. Spencer Library also hosted a wide variety of regional workshops, symposia, and international visitors, such as the Herman Melville Symposium; the Irish Minister of Education; the Irish Ambassador to the United States; Print Council USA; Lassiter/Colored Women's Club; Campbell Conference (science fiction); Mid-America Medieval Conference; and the American Association for Local and State History.

Launched in May 2012, *Inside Spencer: The KSRL Blog* (<http://blogs.lib.ku.edu/spencer/>) promotes Spencer collections and initiatives of interest. Stories from the blog have been featured by local media and shared with a diverse body of readers around the globe. The blog works in tandem with other social media platforms used by KU Libraries, and Spencer collections are often featured in KU Libraries' Facebook, Twitter, Instagram, and Tumblr feeds.

### **CURRENT CONDITIONS AND PRESERVATION CHALLENGES**

Staff at Spencer have been successful at establishing intellectual control over an exceedingly diverse group of materials. Books and journals are cataloged in WorldCat and in the KU Libraries catalog, and online finding aids are produced for manuscript and archival collections. Like most special collections and archives, Spencer Library houses many unprocessed and under-processed collections, but staffing reassignments and creative use of part-time student employees have resulted in more accessible collections.

KU Libraries has had a dedicated preservation program since 1995 when the first preservation librarian was hired. From 1998 to 2018 the Stannard Conservation Laboratory operated in Watson Library; the conservation lab moved to Spencer Library in summer 2018 and updated audiovisual preservation spaces opened in fall 2018. The department is currently staffed by four full-time equivalent (FTE) conservators, one FTE Audiovisual Preservation Specialist, and 2.5 FTE student staff. Conservation Services staff are responsible for providing preservation assessments of entire incoming collections; treatment of individual collection items; vacuuming, dusting, and housing projects; digitizing audiovisual formats; exhibition preparation, installation, and loans; disaster recovery; and environmental monitoring. Conservation Services staff monitor temperature and relative humidity in Spencer Research

Library using fifteen Preservation Environment Monitor (PEM2) dataloggers and web-based eClimateNotebook software, and take periodic visible and ultraviolet light readings. The Libraries have over eight years of cumulative data for Spencer Library spaces. In addition, three dataloggers recording cumulative ultraviolet and visible radiation are installed in the North Gallery permanent exhibit area. The Campus Energy Office monitors eight Johnson Controls sensors added to the stacks in Phase 1 of this project using Metasys building management software system.

State-of-the-art in 1968, the Spencer Research Library building and its mechanical systems are aging. As noted previously, the Spencer's HVAC system is original to the building, with the exception of minor repairs and adjustments over the years. The single-zone HVAC distribution system does not provide the option of separate control of temperature and relative humidity in collection storage areas. Originally designed with set points at 60-65°F and a 50% relative humidity (RH), the system and the facility have degraded to the point that temperatures are now consistently in the low to mid 70s, and the RH typically ranges from 30 to 60% in the building spaces. The Time-Weighted Preservation Index (TWPI)—a measure of an organic material's life expectancy based on the cumulative effects of changes in environment—averages around 45 years for collections storage areas in Spencer Library. The struggle to maintain RH setpoints is particularly challenging. KU Energy Engineer George Werth has told KU Libraries that the HVAC system servicing Spencer Library is “well beyond its intended lifespan,” which would normally be around 25 years.

Designed to maintain an appropriate environment for temperature and humidity control for rare materials, the 1968 HVAC system employs pneumatic thermostats controlling electric reheat emission units in the air distribution system. The campus relies on a centrally distributed steam system for most heating needs, but in Spencer, the only use of steam is to add humidity to the air stream. Spencer and some campus museums are additionally served by a multi-building chilled water system installed in 2014. Supplemental electric radiators are distributed throughout the staff and user-focused parts of the building. Radiators are not installed in collection areas.

Major known preservation issues in Spencer Library, some confirmed or discovered during the Planning Grant, are:

- The downstream ceiling reheats, all of which are controlled by obsolete pneumatic thermostats, are not all functioning properly. IPI consultants discovered that some stay on most of the time, while some never turn on at all. In one space, some vents emitted hot air and others cold. In 2019, KU Facilities staff made some adjustments and repairs to the downstream reheats, resulting in better control of building environments and reduced energy costs. In general, however, because unlinked pneumatic systems do not allow for precise and timely environmental control, additional energy-saving techniques cannot be employed through the AHU or downstream reheats. While there are pneumatic controls and sensors at all reheat locations, there are only two sensors installed in the air handler itself. Because they are not tied into a Building Management System (BMS), the sensors are difficult to identify and repair when they fail.
- There is little to no zoning in the building for warmer office spaces versus colder collection spaces due to antiquated building zone controls. As a result, we cannot keep collections storage in the lower temperature and relative humidity ranges ideal for collection preservation.
- Temperature has stayed fairly consistent over the past five years, from 68 to 76°F, depending on location. Relative humidity (RH) generally shifts seasonally, down into the 30% range in winter and above 60% in summer. Achieving even these conditions, however, requires an enormous amount of energy. The mechanical system manages a dewpoint that does not allow for lower temperatures and controlled relative humidity needed for long-term preservation of the collections.
- Perhaps unsurprising because of its age, the building envelope allows infiltration of outside air, resulting in increased temperature and humidity during the summer months, increasing the load on the existing systems. In Lawrence, Kansas, the summers are hot and muggy and the winters are cold,



dry, and windy. Over the course of the year, the temperature typically varies from 21°F to 90°F and is rarely below 4°F or above 99°F. The wide swings in temperature and relative humidity are a challenge for an aging building envelope.

## **HISTORY OF THE PROJECT**

Library staff have long been aware of various environmental problems in the building and applied for a Sustaining Cultural Heritage Planning Grant to learn more about the major issues and receive recommendations for energy savings while continuing to preserve Spencer's collections. The consultants from Image Permanence Institute, who studied Spencer Library's HVAC system and environmental data over a period of eighteen months, submitted their final report in March of 2019. (See <https://lib.ku.edu/sites/lib.ku.edu/files/docs/reports/mechanical-systems-report.pdf> for the complete report; excerpts of the report appear in the Assessments section.) Major issues identified by the consultants, the strategies we have taken in response to date, and which actions appear in which phase of the overall project appear below.

### **Completed/addressed since Phase 1:**

#### **Excess heating situations**

**Findings:** IPI noted that many spaces in Spencer Library have radiant heaters along the outer edges of the room to complement the HVAC system. The consultants found that some of the heaters or their controlling thermostats were malfunctioning, leading in turn to the reheats in the ceilings not operating and unheated wet or cool air entering the space. These heaters used substantial energy from near constant operation. Some of the heaters were located in small spaces that became extremely hot.

**Actions:** Spencer staff worked with Facilities to turn off heaters in identified small spaces. Disconnecting these radiators has contributed to lower thermal loads in those areas, which in turn has led to stabilized temperature and relative humidity readings.

#### **Radiation (light) mitigation strategies**

**Findings:** IPI consultants observed that window film to block ultraviolet (UV) radiation installed in the North Gallery and conservation lab was not functioning as designed. Shades designed to lower visible light levels in the North Gallery were not consistently used, while other windows in the North Gallery exhibit space did not have shades as they should. Finally, they found that lights in some of the collection storage spaces were routinely left on when staff left those rooms, resulting in unnecessary light exposure to sensitive collections, as well as excess energy use.

**Actions:** A contractor replaced the original windows in the new conservation lab with windows that have an internal UV filtering layer. Data indicate that UV levels are now very low in the conservation lab.

In the North Gallery, three dataloggers that track visible and UV light exposure were installed in fall 2019 to collect more data on cumulative radiation exposure. For stacks lighting issues, conservation staff led a discussion at an all-building meeting about the IPI consultant report. Spencer staff are improving at turning off stacks lights when leaving spaces. KU Libraries has also investigated installation of motion-sensor lighting in some stacks areas, but the low height of the bookstacks makes installing appropriate sensors difficult. We hope to lower thermal loads throughout the building with these strategies to place fewer demands on the mechanical systems.

#### **Testing modified shutdowns**

**Findings:** IPI and KU Libraries experimented with nightly setbacks of the mechanical systems at various points during the testing period to determine if and how Spencer's storage environments might be affected. Densely packed library and archival collections are slow to respond to the effects of

changing temperature and relative humidity, and our experience is that these passive changes lead to energy and cost savings.

During the Planning Grant, we experimented with both winter and summer overnight setbacks over a period of two years. Over the winter months in 2017-2018, the team experimented with reducing the setting of the HVAC system (overnight setback mode) for thirteen hours at a time to save energy. The building maintained temperature and relative humidity at acceptable levels over the winter months through this energy-saving practice. However, similar tests in April-June 2018 indicated that the building did not maintain temperature and relative humidity in the space at nights, nor did it recover acceptable levels of temperature and relative humidity throughout the day. After discussion with the KU energy engineer George Werth and the IPI consultants, we modified the shutdowns for a shorter period of time (six hours), starting in later hours when the heat load had somewhat dissipated. The data still indicated that the building systems could not recover after the daytime settings were activated. The summer shutdowns were discontinued at that time and resumed in the fall after the hottest and most humid summer months had passed. The consultants encouraged further testing during the summer months to see if a useful shutdown could be achieved, but tests in summer 2019 presented similarly unacceptable results. Winter shutdowns, however, were considered successful and have been continued. (See Assessments for example graphs of setback testing.)

**Actions:** We are pleased by the energy savings that have resulted from nightly shutdowns. Werth noted that because of energy improvements in recent years, such as the night setbacks, increased maintenance attention from Facilities staff, and improved metering on the chilled water line, the “energy costs [for Spencer Library] dropped from \$167,113 in 2016 annually to \$99,015 in 2019” (a 40% reduction in energy costs). KU Libraries is committed to using passive approaches whenever possible and will continue to implement winter shutdowns, as approved by the IPI consultants, as well as test controlled shutdowns in the shoulder seasons of spring and fall.

## **Phase 2: Current Proposal**

### **Make improvements to mechanical system: Replace reheats and rebalance system**

**Findings:** Some steps should be taken to improve the current mechanical system, such as cleaning out the outside air intake, better sealing the AHU doors, better filtering, reheat replacement, and rebalancing the system.

Note: Funds earmarked in the Planning Grant for additional equipment and testing were used to install two temperature sensors in each of four areas of the Spencer collections stacks to supplement the meager two original sensors in the building, both of which were located in the return air streams in the machine room. We hoped that by installing additional sensor points in the collections stacks the campus energy team could have a better sense of how the air handling unit in Spencer Library functioned and would be better able to respond to anomalies.

**Actions:** Many of these recommendations are part of the current grant proposal, in particular replacing the pneumatic controls with more energy-efficient digital devices in Spencer Library collections areas and rebalancing the system at the end of the endeavor. Facilities has removed overgrown vegetation and extra debris from the outside air intake. Issues with the AHU will be addressed in Phase 3 of the project.

## **Phase 3 (Future Project):**

### **Install building management system (BMS)**

**Findings:** Facilities will have more control over the Spencer system when a BMS is installed.

**Actions:** We are taking the first steps toward this recommendation by replacing the pneumatic controls with digital, replacing original reheats, and undertaking air balancing at the end of this project. A final BMS would be an end-product of Phase 3, when the air handling unit is replaced. Johnson

Controls products use Metasys software, which we are currently using for the few sensors currently in the building.

#### **Identify water issues in the tunnels**

**Findings:** The two tunnels under Spencer that supply conditioned air to the building are not properly sealed, allowing for water intrusion at certain times of the year.

**Actions:** This problem will be fully addressed when the air handling unit is eventually replaced. In the meantime, KU Libraries will work with Facilities staff to determine the causes related to this issue.

#### **Replace mechanical system**

**Findings:** The current air handling unit is 51 years old and does not maintain a preservation environment for the collection, especially in the summer.

**Actions:** This recommendation is the ultimate goal, Phase 2 of which is covered in this grant proposal. At this time, replacing the back-end of the system, the AHU, is cost-prohibitive, but replacing most of the front-end (digital controls and reheats) will result in a faster turnaround time when the AHU is replaced during Phase 3, placing the collections at lower risk when that happens. In the meantime, the upgraded controls will provide energy savings and greater control of individual spaces, using the existing AHU.

#### **METHODS AND STANDARDS**

Peter Herzog, in a 2011 conference held at the National Archives, characterizes the sustained optimal preservation storage environment as “when your unique climate control system consistently produces its own best possible storage environment at the least possible consumption of energy” (<https://www.archives.gov/files/preservation/conferences/2011/presentations/herzog.pdf>). The optimal conditions, he notes, are those with the “best possible climate, while doing the least possible work, on the least possible volume of air, for the least possible time.” In Phase 2 of our project, which includes testing and balancing of the current HVAC system, we hope to add to our understanding of whether the system is doing more work than necessary and with more air than necessary. We continue to strive to reduce energy consumption while maintaining appropriate preservation environments for Spencer’s collections.

As noted previously, in Spencer Library, there is one air handling unit (AHU) that supplies conditioned air to the entire building. For fine-tuning of different spaces within the building, the original system has relied on approximately 64 ceiling duct reheats, along with 129 dampers and 129 space thermostats, and perimeter radiators in some areas. The reheat units are controlled by an outdated pneumatic system that should open and close dampers in the ceilings to supply conditioned air. The IPI consultants found that many of the reheats have malfunctioned, and some dampers are always closed and others always open. It is costly to repair these units, as each one must be located in the ceiling by a technician and repaired individually. Younger HVAC technicians are not trained in pneumatic systems, making Spencer Library’s system an increasing concern for the future. At the current time there is no way to remotely control these reheats, adding to the cost of maintaining Spencer’s systems.

Therefore, for this grant initiative, we hope to replace the 47 pneumatically controlled reheats in collection storage areas with modern electric reheats, as well as variable air volume (VAV) dampers and direct digital controls (DDC). In preparation for Phase 2 of this project, George Werth, Campus Energy Engineer, walked through the building, using existing drawings of the building’s HVAC system to confirm location of ceiling reheats and conceptualize the extent of the project before discussing the project with Johnson Controls, which is contracted to the University of Kansas for projects of this type. Werth has selected a product that allows the installer to use existing ductwork, resulting in reduced labor costs. The installer will remove the existing reheat and damper boxes and slide the new versions

into the existing spaces. These boxes contain a reheat coil, damper to control air flow, and a digital sensor (see schematic below and technical specifications of proposed equipment in the Specifications section). The updated reheat boxes will afford a much greater level of control, allowing temperature and humidity adjustments to be made and monitored remotely and for all collection storage zones.

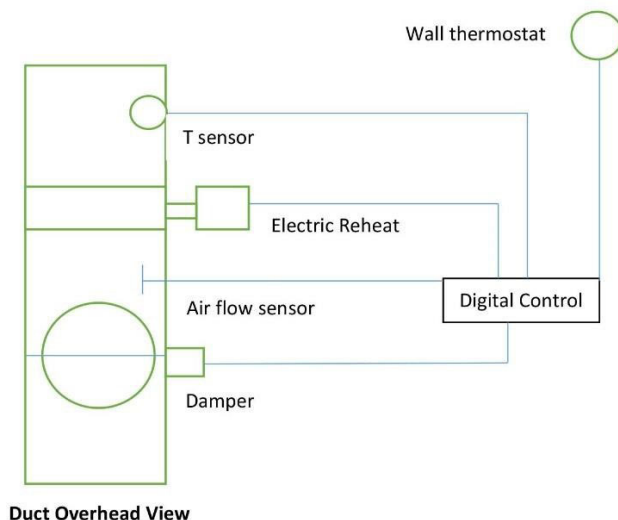

### Schematic of the components of the proposed duct upgrades

A first step in this project will be to test and balance the system as it currently operates, in order to evaluate the air and water flow to equipment and check all ceiling diffusers. The contractor, Doyle Field Services, will test and document the total air supply for the air handling unit and its distribution system. It will also test the temperature controls for the automatic control dampers, the reheats, and airflow totals. This endeavor will provide information on which areas of the collections currently have sufficient airflow and if not, why not. It will also inform the next steps, making it easier to specify the type and size of dampers required in various parts of the ductwork. A study of this magnitude has not happened since the building opened in 1968 and current data is required at the outset of the project. Doyle Field Services is certified by the National Environmental Balancing Bureau (NEBB) and is contracted with the University of Kansas for all testing and balancing on campus.

Once sufficient data has been collected, Johnson Controls will design and manufacture the equipment specific to the requirements of Spencer Library and proceed with installation of the electric reheats, dampers, airflow sensors, and digital controls in each ceiling location in collections stacks areas. During installation of the VAV box units, airflow will be turned off a room at a time. Conservation and the KU Energy Office will both monitor the building particularly closely during that phase of the project. Fortunately, we have experience with such a situation: In winter 2018-2019, the HVAC was offline during electrical upgrades, for up to twelve hours at a time. We chose to complete this project during the winter months when temperature and relative humidity shifts would head downward rather than up, causing less potential damage to the collections. In fact, however, the data indicated that both the temperature and relative humidity remained steady during those incidents (see the Assessments section for graphs of a successful winter shutdown study). Therefore, we hope to schedule installation (up to four months) over the late fall and winter months to minimize possible temperature and relative

humidity fluctuations.

During installation of the new equipment in the ceilings and ductwork, the Head of Conservation will regularly monitor which collections will need to be covered or possibly moved before any drilling or ceiling tile work occurs in collection spaces. This work will require regular discussion with the contractors to stay apprised of where in the building the work will happen, in order to anticipate and be prepared for upcoming installation. When the project begins, Conservation staff will meet with Johnson Controls staff to discuss care of collections and safe practices in the stacks. Plastic sheeting will be used to cover collections that remain in-situ, and Conservation staff will organize any collection moves that may be required. In addition, the team will review the disaster preparedness plan at the outset of the project. Spencer Library has a disaster kit on each floor of the building, as well as additional supplies in the conservation lab that is located in the building. Conservation staff have extensive experience with disaster recovery. In addition, during the installation phase of the project, environmental data will be pulled weekly (or more frequently, if needed) and reviewed by the Head of Conservation.

At the end of the project, Doyle Field Services will once again test and balance the new system to ensure that it is functioning properly, plus conduct a final commissioning. Conservation and the KU Energy Office will spend the next six to seven months monitoring the temperature and relative humidity in the collection spaces to confirm that it is working properly and experiment again with nightly setbacks. Baker and Miller will write the final NEH White Paper when the testing is completed. George Werth estimates that the steps outlined in Phase 2 will result in a 10-12% energy savings annually, based on energy savings garnered in other campus buildings that were switched from pneumatic controls to variable air volume (VAV) dampers with direct digital controls. In combination with the roughly 40% reduction over the past three years, thanks to the nightly setbacks and other building maintenance, energy savings for Spencer Library will be significant. Werth will track energy costs during and after Phase 2.

## **WORK PLAN**

The proposed project would require approximately 22 months. The timeline has been established so that installation occurs during the winter months, in order to ensure the fewest possible disruptions to the collection environment should parts of the HVAC system be offline during the installation of new equipment. As a result, the project would not begin in earnest until spring 2021. The project consists of members of the Environmental Management Team, Doyle Field Services, and Johnson Controls. Throughout the project the team would meet monthly during the planning phase and biweekly during the installation phase to monitor the spaces, review the data, and receive updates on project progress.

<b><i>Date</i></b>	<b><i>Activity</i></b>	<b><i>Responsible parties</i></b>
Throughout	• Monthly meetings during initial and final test and balance phases	KU team members
	• Biweekly meetings during installation and analysis phases	KU team and contractors
	• Temperature and relative humidity monitoring in collection spaces	Baker, Werth
	• Energy use monitoring	Werth, Miller
	• Periodic reporting on progress, via blog and other KU Libraries social media	Baker

April 2021 (1 month)	<ul style="list-style-type: none"> <li>• Team meeting to kick off project</li> <li>• KU staff gather environmental data, collection assessments, prior environmental reports, blueprints, building plans, and other relevant data, and make them accessible to all members of the project team</li> </ul>	All team members  Baker, Miller, Werth, Mohr
May-June 2021 (1-2 months)	<ul style="list-style-type: none"> <li>• Section 106 Review for 50+ year-old building, if warranted. (No changes will be made to the building façade)</li> </ul>	Baker, Miller, Mohr, campus architect
July-August 2021 (1 ½ months)	<ul style="list-style-type: none"> <li>• Test and balance system, checking diffusers, ductwork, airflow, and water flow in collections spaces</li> </ul>	Doyle Field Services
September 2021 (1 month)	<ul style="list-style-type: none"> <li>• Design final drawings based on findings from testing/balancing</li> </ul>	Johnson Controls
October 2021 (1 month)	<ul style="list-style-type: none"> <li>• Official direct negotiated bid for installation following University of Kansas procedures</li> </ul>	Werth, Miller, Johnson Controls
November 2021-February 2022 (4 months)	<ul style="list-style-type: none"> <li>• Installation of electric reheats, dampers, controls in collection areas</li> </ul>	Johnson Controls, with oversight from KU team
February 2022-May 2022 (3 months)	<ul style="list-style-type: none"> <li>• Final testing and balancing; commissioning of new system</li> </ul>	Doyle Field Services, Werth, Miller, Baker
May 2022-December 2023 (7 months)	<ul style="list-style-type: none"> <li>• Team review and assessment of the project</li> <li>• Nightly setback testing in collection areas with new equipment in place</li> </ul>	Baker, Miller, Werth, Conrad, Mohr, Whittaker
December 2022-January 2023 (1 month)	<ul style="list-style-type: none"> <li>• After experiencing various seasons with new equipment and updated winter/shoulder season setbacks, complete white paper</li> </ul>	Baker, Miller

**PROJECT TEAM (Environmental Management Team)**

For this project an interdisciplinary Environmental Management Team will be assembled to oversee the project, representing a wide variety of campus expertise and following guidelines in Image Permanence Institute’s *Guide to Sustainable Preservation Practices for Managing Storage Environments* (2012) for effectively organizing teams of this nature. The team is composed of individuals who worked together

successfully and efficiently in Phase 1, during the Planning Grant time period. Librarians understand the collections and the effects of the aging HVAC system on the collections. The humanities scholar understands the significance of Spencer's collections in the broader context of academic scholarship. Conservation staff have monitored the building for years and bring knowledge of preservation standards and trends. The KU Energy Office staff deeply understand the mechanical system in Spencer Library, and bring years of experience in tweaking the systems to respond to changing conditions and tracking energy savings during and after the project. Facilities Planning and Development expertise will aid in linking this project with campus system design specifications.

Johnson Controls and Doyle Field Services will serve as contractors for the proposal. Both companies have earned contracts with the University of Kansas based on a rigorous vetting process, and both have successfully completed similar projects for the University of Kansas. Proposed participants are:

- Whitney Baker, Co-Principal Investigator, is Head of Conservation Services at KU Libraries, and has worked in preservation for over 20 years. A trained conservator, she oversees all preservation efforts for KU Libraries, including environmental monitoring. She is a Fellow in the American Institute for Conservation.
- Kathryn Conrad, Associate Professor of English, works closely with the Irish collections at Spencer Library and will represent the perspective of a humanities scholar. Conrad was a particularly enthusiastic participant on the Planning Grant team and looks forward to learning more about HVAC systems.
- Kent Miller, Co-Principal Investigator, Associate Dean, KU Libraries, is responsible for buildings and operations for the entire KU Libraries system. He brings decades of experience in all areas of library operations, along with specific knowledge of the Spencer building and complexities of campus maintenance and operations.
- Gary Mohr, Project Director and Mechanical Engineer for University of Kansas Facilities Planning & Development, will ensure coordination of planning with appropriate campus entities and address the maintenance and sustainability of subsequent work.
- George Werth, Campus Energy Engineer in KU's Operations Energy Office, oversees facilities data monitoring system for all campus buildings, and will be crucial in identifying cost savings of proposed adjustments to the Spencer Library mechanical systems.
- Beth Whittaker, Assistant Dean for Distinctive Collections, leads Spencer Research Library and is responsible for all its collections and services. She has coordinated and implemented many building renovations in Spencer Library.
- Tom Doyle, P.E., NEBB Certified Commissioning Agent, Doyle Field Services, will act as the principal-in-charge and will be the responsible party for all aspects of testing, balancing, and commissioning.
- Tim Swope, from Johnson Controls, will be in charge of manufacture, installation, and programming of the new devices.

#### **PROJECT RESULTS AND DISSEMINATION**

The implementation project will result in a significant upgrade in the collection storage environment for Spencer Library, ensuring that malfunctioning reheats in the ductwork of collection spaces are replaced with ones that function properly and improving temperature and humidity levels in those spaces. In addition, this step will result in significant energy savings and will represent a major step forward in updating the HVAC system in Spencer Library. The ultimate goals, of course, are to protect the collections of Spencer Research Library while reducing energy costs.

In addition to completing the required White Paper for NEH that will outline procedures, energy

savings, and lessons learned, the KU project team will share the results of this case study with colleagues. The challenges faced by the Spencer Library are not unique in the field, and the experience gained from this interdisciplinary assessment will be of broad interest—especially regarding any garnered energy savings. Presentations or poster sessions would be submitted to our various professional conferences, such as the Sustainability Committee program at the American Institute for Conservation and the Preservation Administration Interest Group at the American Library Association annual meetings.

Beyond the more traditional academic methods for disseminating the results of this project, KU Libraries would share regular updates on progress of the project via the Spencer Library blog, as was modeled during the Sustaining Cultural Heritage Collections Planning Grant, and other KU Libraries social media outlets. In addition, the project would serve as a real-world learning opportunity for graduate students in KU's Museum Studies program, both as it would be incorporated into the curriculum of a spring 2022 KU graduate class, *Conservation Principles and Practice* (taught by Baker), and for the senior conservation student assistant in Conservation (usually a museum studies student), who collects the temperature and relative humidity data and regularly discusses it with the Head of Conservation.